

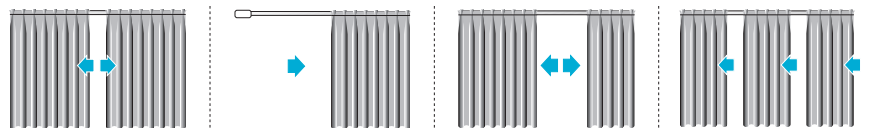

3.1.2

Separè 458

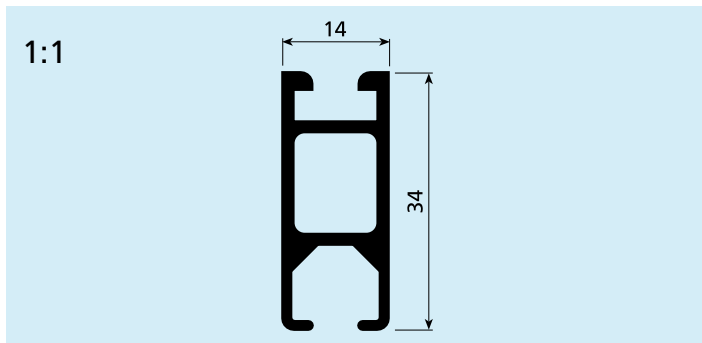



USE UTILIZZO - USE - USO
USO - UTILISATION - ANWENDUNG
GEBRUIK - ИСПОЛЬЗОВАНИЕ

SISTEMA PER TENDE ARRICCIATE AD USO SEPARAZIONE DI AMBIENTI INDICATO PER DOCCE, AMBIENTI PROFESSIONALI ED OSPEDALIERI

Azionamento a strappo. Indicato per tendaggi L max 800 cm ed H 300 cm di peso sino a 6 kg. L'apertura della tenda può essere centrale, laterale, multipla o asimmetrica. Il sistema è indicato per installazioni a soffitto, a parete ed in libera sospensione tramite specifici tiranti, preferibilmente con profilo a vista. Il sistema permette la realizzazione di profili curvi a 90° o centinati ad ampio raggio. Lo scorrimento è garantito da scivoli autolubrificanti in polietilene o da scorrevoli a rullo per i tendaggi al limite della portata.

DRAPED CURTAIN SYSTEM USED FOR SEPARATING AREAS. SUITABLE FOR SHOWERS AND FOR PROFESSIONAL AND HOSPITAL ENVIRONMENTS

Hand operated. For use with curtains 800 cm W max. and 300 cm H weighing up to 6 kg. The curtain opening can be central, lateral, multiple or asymmetric. The system is suitable for ceiling and wall installations and free hanging ones using specific hangers, preferably with exposed track.

The system allows tracks curved through 90° or with wide radius centring to be installed.

Sliding is guaranteed by self-lubricating polyethylene slides or by roller gliders for curtains at the load limit.

SISTEMA PARA CORTINAS FRUNCIDAS PARA SEPARACIÓN DE AMBIENTES, ADECUADO PARA DUCHAS, AMBIENTES PROFESIONALES Y HOSPITALES

Accionamiento manual. Adecuado para cortinas de anchura máx. 800 cm y altura máx. 300 cm, de peso hasta 6 kg.

La apertura de la cortina puede ser central, lateral, múltiple o asimétrica. Sistema adecuado para montajes en techo, en pared o en libre suspensión mediante tirantes específicos, preferiblemente con perfil a la vista.

Este sistema permite realizar perfiles curvos en 90° o curvados en amplio ángulo. El deslizamiento se efectúa mediante correderas deslizantes autolubricadas de polietileno o correderas de ruedecitas para las cortinas más pesadas.

SISTEMA PARA CORTINAS FRANZIDAS PARA USO COMO SEPARADORES DE AMBIENTES. INDICADO PARA DUCHES, AMBIENTES PROFISSIONAIS E HOSPITALARES

Accionamento à mão. Indicado para cortinas com largura máxima de 800 cm, altura 300 cm e peso até 6 kg.

A abertura da cortina pode ser central, lateral, múltipla ou assimétrica. O sistema é indicado para instalações no tecto, na parede e em suspensão livre mediante utilização de tirantes específicos, de preferência com perfil à mostra. O sistema permite fazer instalações com curvas de 90° ou curvaturas de raio amplo. O deslizamento é garantido por deslizadores de polietileno autolubrificantes ou por corredeiras de rolo para cortinas no limite máximo de peso.

SYSTÈME POUR RIDEAUX DRAPÉS DE SÉPARATION DE LOCAUX INDIQUÉ POUR DOUCHES, LOCAUX PROFESSIONNELS ET SECTEUR HOSPITALIER

Actionnement par tirage manuel. Préconisé pour rideaux L Max 800 cm et H 300 cm d'un poids jusqu'à 6 kg.

L'ouverture du rideau peut être centrale, latérale, multiple ou asymétrique. Le système est approprié pour installation plafond, de face et suspendu par tringles spéciales, de préférence avec profilé visible. Le système permet la réalisation de profils cintrés à 90° ou à grand rayon. Le coulisement est assuré par glissières autolubrifiantes en polyéthylène ou par rouleurs pour les rideaux atteignant le poids maximum.

VORHANGSYSTEM ZUR RAUMTRENNUNG VON DUSCHEN, ARBEITSBEREICHEN UND IN KRANKENHÄUSERN

Zugbetätigung. Für Gardinen mit max. L 800 cm und H 300 cm, Gewicht bis 6 kg. Mögliche Öffnungsarten: zentral, seitlich, vielseitig oder asymmetrisch. Das System ist für Decken- und Wandmontage sowie freihängende Montage mit Deckenabhängung, vorzugsweise mit sichtbarem Profil, geeignet. Das System ermöglicht das Ausführen von 90°-Kurven oder Kurven mit großem Kurvenradius.

Selbstschmierende Polyethylengleiter oder Rollgleiter für Gardinen, deren Gewicht fast an der Tragfähigkeitsgrenze liegt, gewährleisten einwandfreies Gleiten.

GORDIJNRAIL VOOR AFSCHEIDINGEN. GEBRUIK VOOR DOUCHES EN BEDAFSCHERMING IN KLINIEKEN

Handbediend. Gebruik voor gordijnen tot 8 m breed en 3 m hoog met maximum gewicht tot 6 kg.

Openen van het gordijn kan centraal of lateraal, of asymmetrische verdeling. Bevestiging tegen plafond of wand, alsook vrijhangend.

De rail kan verbogen worden op 90° of op grote straal





Het glijden wordt gegarandeerd door zelfsmurende polyethyleen glijders of rollers voor gordijnen aan het limietgewicht.

СИСТЕМА ДЛЯ ДРАПИРОВАННЫХ ШТОР, ПРЕДНАЗНАЧЕННЫХ ДЛЯ РАЗДЕЛЕНИЯ ПОМЕЩЕНИЙ, РЕКОМЕНДУЕТСЯ ДЛЯ ДУШЕЙ, ОФИСНЫХ И БОЛЬНИЧНЫХ ПОМЕЩЕНИЙ

Привод в действие вручную. Рекомендуется для штор Д. 800 см макс. и В. 300 см с весом до 6 кг.

Открытие штор может быть центральным, боковым, в нескольких точках и несимметричным. Эта система рекомендована для потолочной, настенной установки или для свободного подвешивания при помощи специальных тяг, желательно с видимым профилем.

Система позволяет выполнять повороты на 90° или с большим радиусом. Движение осуществляется посредством самосмазывающихся полозков из полиэтилена или роликовых бегунков для штор, вес которых приближается к максимальному.

Kg ref. 4263											Kg ref. 4263										
	2m	4m	6m	8m	10m	12m	14m	16m	18m	20m		2m	4m	6m	8m	10m	12m	14m	16m	18m	20m
	7 Kg	11 Kg	8 Kg									3 Kg	5 Kg	3 Kg							
	6 Kg	9 Kg	7 Kg									3 Kg	5 Kg	3 Kg							



3.1.4

Separè 458



CARATTERISTICHE TECNICHE - SPECIFICATIONS
 CARACTERÍSTICAS - CARACTERÍSTICAS - CARACTÉRISTIQUES
 EIGENSCHAFTEN - KARAKTERISTIEKEN - ХАРАКТЕРИСТИКИ

- Profilo in lega d'alluminio estrusa 6060 T6 UNI 8278
 - Larghezza 14 mm; Altezza 34 mm
 - Canale di scorrimento: 6 mm
 - Raggio di curvatura minima:
curve a 90°: 12 cm - curve ad ampio raggio: 50 cm
 - Finitura superficiale:
verniciatura poliester bianco RAL 9016 - anodizzato argento
 - Accessori in acetilica autolubrificante
- 6060 T6 UNI 8278 extruded aluminium alloy track
 - Width 14 mm; Height 34 mm
 - Sliding channel: 6 mm
 - Minimum radius of curvature:
90° curves: 12 cm - wide radius curves: 50 cm
 - Surface finish: RAL 9016 white polyester paint - silver anodised
 - Self-lubricating acetylic accessories
- Perfil en aleación de aluminio extruido 6060 T6 UNI 8278
 - Anchura 14 mm - Altura 34 mm
 - Canal de deslizamiento: 6 mm
 - Ángulo de curvatura mínima:
curvas en 90°: 12 cm - curvas de ángulo amplio: 50 cm
 - Acabados de la superficie: pintura poliéster blanca RAL 9016; anodizado plata
 - Accesorios de acetálico autolubricante
- Perfil de liga de alumínio extrudido 6060 T6 UNI 8278
 - Largura 14 mm; Altura 34 mm
 - Calha de deslizamento: 6 mm
 - Raio de curvatura mínimo:
curvas de 90°: 12 cm - curvas de raio amplo: 50 cm
 - Acabamento superficial:
tinta de poliéster branca RAL 9016 - anodizado prateado
 - Acessórios de resina acetálica autolubrificante
- Profil en alliage d'aluminium extrudé 6060 T6 UNI 8278
 - Largeur 14 mm; Hauteur 34 mm
 - Rail de coulissement: 6 mm
 - Rayon minimum: courbes à 90°: 12 cm - courbes à grand rayon: 50 cm
 - Finition superficielle: peinture polyester blanc RAL 9016 - anodisé argent
 - Accessoires en résine d'acétal autolubrifiante
- Profil aus extrudierter Alu-Legierung 6060 T6 UNI 8278
 - Breite 14 mm; Höhe 34 mm - Laufkanal: 6 mm
 - Kleinster Biegeradius:
90°-Kurven: 12 cm - Kurven mit großem Radius: 50 cm
 - Oberflächen-Finish: Polyesterlackierung Weiß RAL 9016 - Alu eloxiert
 - Zubehör aus selbstschmierendem Acetal
- 6060 T6 UNI 8278 aluminium profiel
 - Breedte 14 mm - hoogte 34 mm - glijkanaal 6 mm
 - Minimum straal van verbuiging 90°: 12 cm, grote straal: 50 cm
 - Oppervlaktebehandeling: RAL 9016 wit polyesterlak, zilver geanodiseerd - Zelfsmerende acetyl onderdelen
- Профиль из экструдированного алюминиевого сплава 6060 T6 UNI 8278
 - Ширина 14 мм; Высота 34 мм
 - Желоб: 6 мм
 - Минимальный радиус поворота:
повороты на 90°: 12 см - повороты с большим радиусом: 50 см
 - Отделка поверхности:
полиэфирная окраска в белый цвет RAL 9016 - анодирование серебро
 - Принадлежности из самосмазывающейся ацеталовой пластмассы

DIVISIONE AMBIENTI

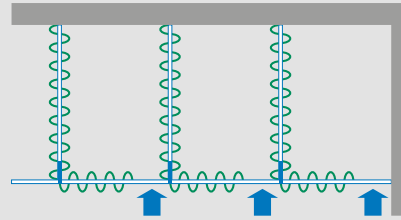

PARTITIONING
 SEPARACIÓN AMBIENTES
 SEPARAÇÃO DE AMBIENTES
 SÉPARATION
 RAUMABTRENnungen
 AFSCHEIDINGEN
 РАЗДЕЛЕНИЕ ПОМЕЩЕНИЯ

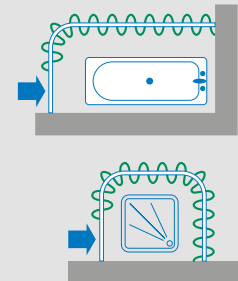
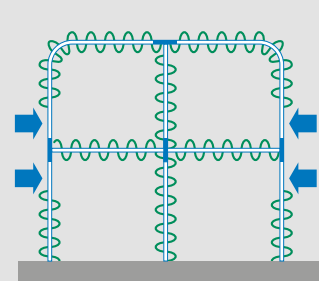
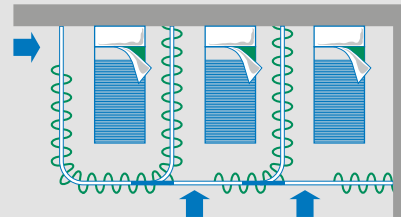

SOSPENSIONE QUADRI

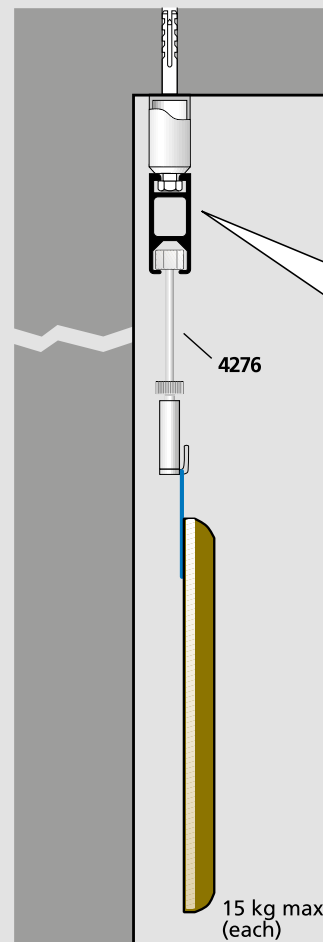

PICTURES HANGING
 SUSPENSIÓN CUADROS
 SUSPENSÃO DE QUADROS
 SUSPENSION CÂDRES BILDER
 AUFHÄNGUNG
 SCHILDERIJ OPHANGING
 ПОДВЕШИВАНИЕ КАРТИН

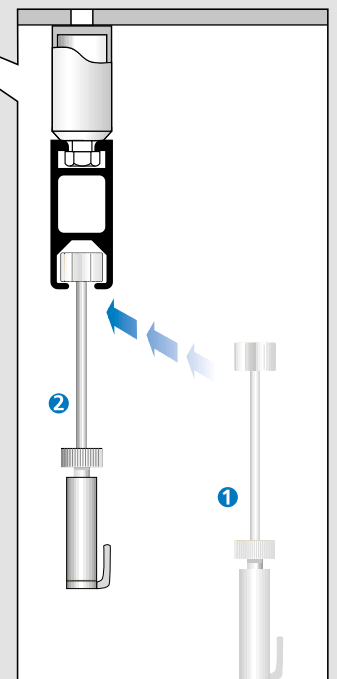

15 kg max
(each)

INSTALLAZIONE

INSTALLATION
 INSTALACIÓN
 INSTALAÇÃO
 INSTALLATION
 INSTALLATION
 INSTALLATIE
 УСТАНОВКА

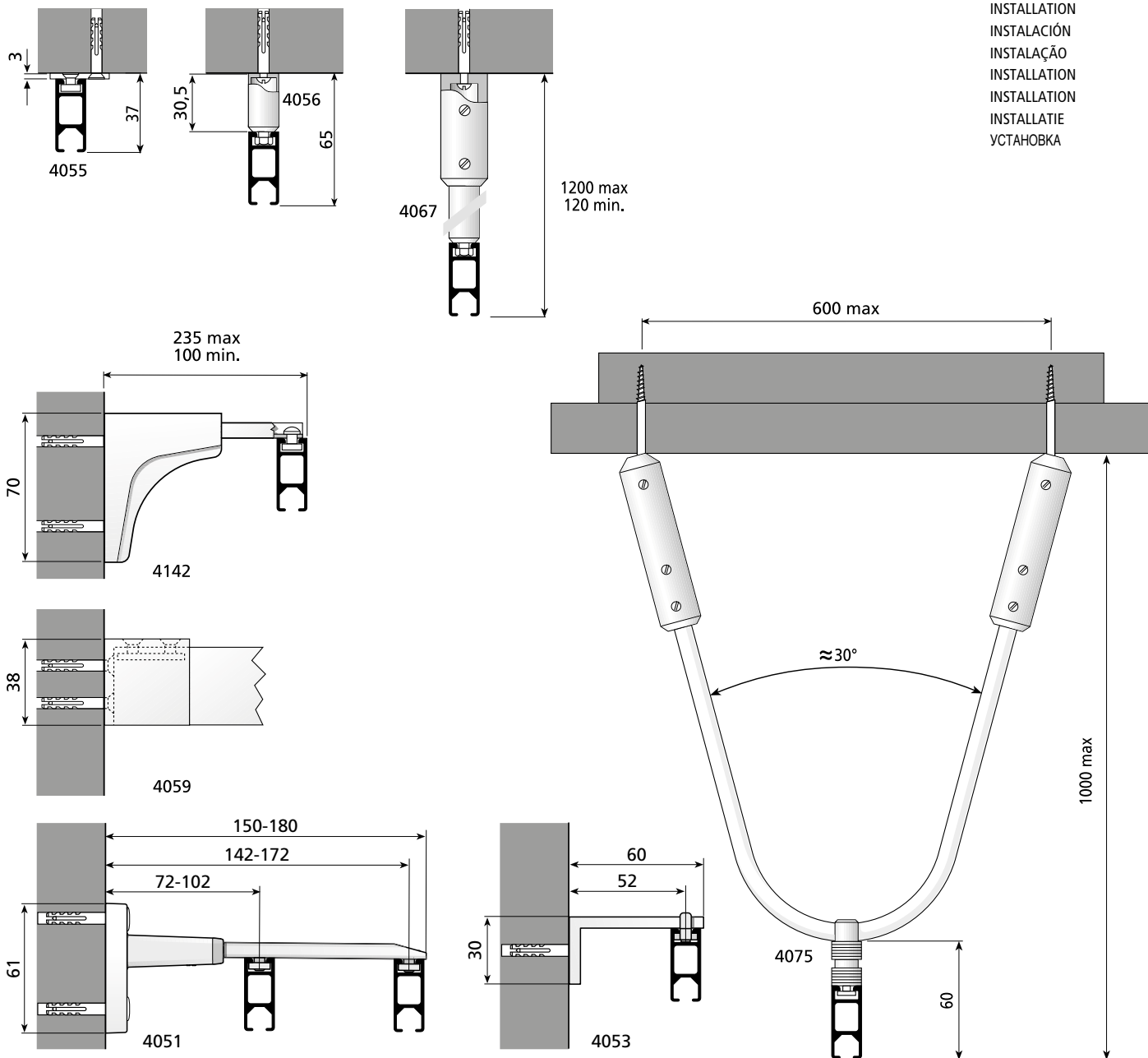

CURVE



max 90°
 R. 12 cm

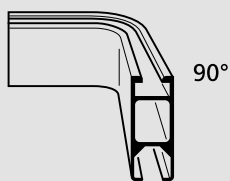

art. 9844
 (Sec. C)



art. 9801
 art. 9802
 art. 98023
 (Sec. C)



art. 9944
 (Sec. C)

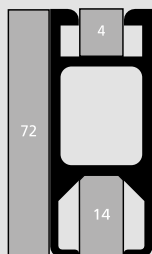

R min.
 50 cm



art. 9845
 (Sec. C)



art. 9805
 (Sec. C)



art. 9945
 (Sec. C)



BENDING
 CURVAS
 CURVAS
 COURBAGE
 BOGEN
 BUIGEN
 ИЗГИБ



3.1.6

Separè 458

