

# Teatro 404

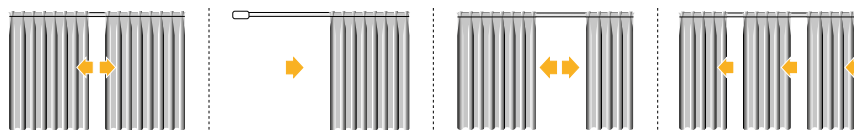





**CARATTERISTICHE TECNICHE - SPECIFICATIONS  
CARACTERÍSTICAS - CARACTERÍSTICAS - CARACTÉRISTIQUES  
EIGENSCHAFTEN - KARAKTERISTIEKEN - ХАРАКТЕРИСТИКИ**

- Profilo in lega d'alluminio estrusa 6060 T6 UNI 8278
  - Larghezza 57 mm; Altezza 32,5 mm
  - Canale di scorrimento 6,5 mm
  - Finitura superficiale:  
verniciatura poliester bianco RAL 9016
  - Carrucole in termoplastico antiurto con cuscinetti a sfera
  - Accessori in acetica autolubrificante
- 6060 T6 UNI 8278 extruded aluminium alloy track
  - Width 57 mm; Height 32.5 mm
  - Sliding channel 6.5 mm
  - Surface finish:  
RAL 9016 white polyester paint
  - Shockproof thermoplastic pulleys with ball bearings
  - Self-lubricating acetylic accessories
- Perfil en aleación de aluminio extruido 6060 T6 UNI 8278
  - Anchura 57 mm - Altura 32,5 mm
  - Canal de deslizamiento 6,5 mm
  - Acabado de la superficie:  
pintura poliéster blanca RAL 9016
  - Poleas en termoplástico endurecido con cojinetes de bolas
  - Accesorios de acetálico autolubrificante
- Perfil de liga de aluminio extrudido 6060 T6 UNI 8278
  - Largura 57 mm; Altura 32,5 mm
  - Calha de deslizamento 6,5 mm
  - Acabamento superficial: tinta de poliéster branca RAL 9016
  - Polias de material termoplástico anti-choque com rolamentos de esferas
  - Acessórios de resina acetálica autolubrificante
- Profil en alliage d'aluminium extrudé 6060 T6 UNI 8278
  - Largeur 57 mm; Hauteur 32,5 mm
  - Rail de coulissement 6,5 mm
  - Finition superficielle:  
peinture polyester blanc RAL 9016
  - Poulies en matériau thermoplastique antichoc avec coussinets à billes
  - Accessoires en résine d'acétal autolubrificante
- Profil aus extrudierter Alu-Legierung 6060 T6 UNI 8278
  - Breite 57 mm; Höhe 32,5 mm
  - Laufkanal 6,5 mm
  - Oberflächen-Finish:  
Polyesterlackierung Weiß RAL 9016
  - Umlenkungen aus stoßfestem Thermoplast mit Kugellagern
  - Zubehör aus selbstschmierendem Acetal
- Geëxtrudeerd aluminium profiel 6060 T6 UNI 8278
  - Breedte 57 mm; hoogte 32,5 mm
  - Glijkanaal 6,5 mm
  - Oppervlaktebehandeling:  
polyesterlak wit RAL 9016
  - Poelies in schokvrij thermoplast en rollen met kogellagers
  - Onderdelen in zelfsmarend acetyl
  - Профиль из экструдированного алюминиевого сплава 6060 T6 UNI 8278
  - Ширина 57 мм; Высота 32,5 мм
  - Желоб 6,5 мм
  - Отделка поверхности:  
полиэфирная окраска в белый цвет RAL 9016
  - Шкивы из противоударного термопласта с шарикоподшипниками
  - Принадлежности из самосмазывающейся ацеталовой пластмассы

## INSTALLAZIONE

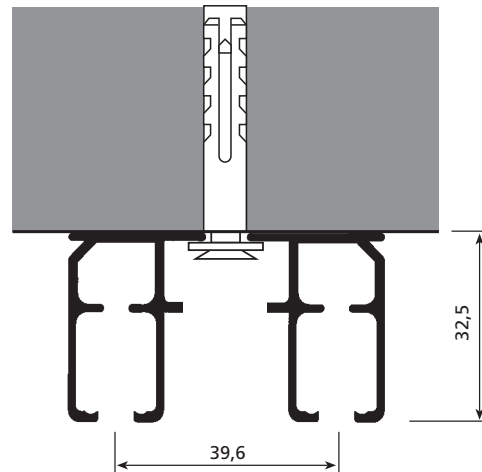

INSTALLATION  
INSTALACIÓN  
INSTALAÇÃO  
INSTALLATION  
INSTALLATION  
INSTALLATIE  
УСТАНОВКА

## CONFEZIONI CONSIGLIATE

A	RAPPORTO DI ARRICCIATURA THE SPACE BETWEEN THE PLEATS RAPPORT DE FRUNCIDO RELAÇÃO DE FRANZIDO INDIQUE LA DISTANCE ENTRE PLUS GIBT DEN RAFFRAPPORT AN GEEFT DE AFSTAND TUSSEN DE PLOOIEN AAN ВИД ДРАПИРОВКИ	SUGGESTED STYLES OF CURTAINS TIPOS DE CONFECCIÓN TIPOS DE CORTINAS ACONSELHADOS CONFECTION CONSEILLÉE EMPFOHLENE VORHANGBÄNDER AANBEVOLEN CONFECTIE МОДЕЛЬ
B	NASTRO - TAPE CINTA - FITA GALON - BAND LINT - ЛЕНТА	

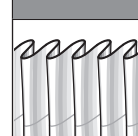
	A	B
	1:2	art. 776 - h 80 mm art. 795/... - h 80 mm

## INGOMBRI

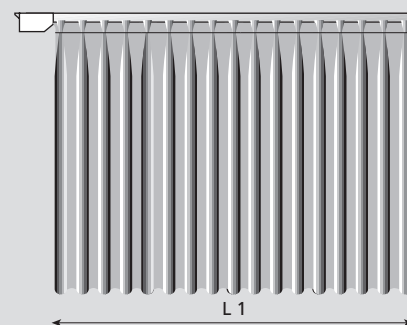

OVERALL  
DIMENSIONS  
ESPORES  
DIMENSÃO  
ENCOMBEMENT  
RAUMBEDARF  
PAKKET  
ГАБАРИТЫ



**L2 ≈ 18% L1**

